

# LPA系列可编程宽范围线性 电源使用说明书

本说明书适用于本系列以下型号:

LPA1501 / LPA2002 / LPA3001 / LPA3005 / LPA6003 / LPA6005

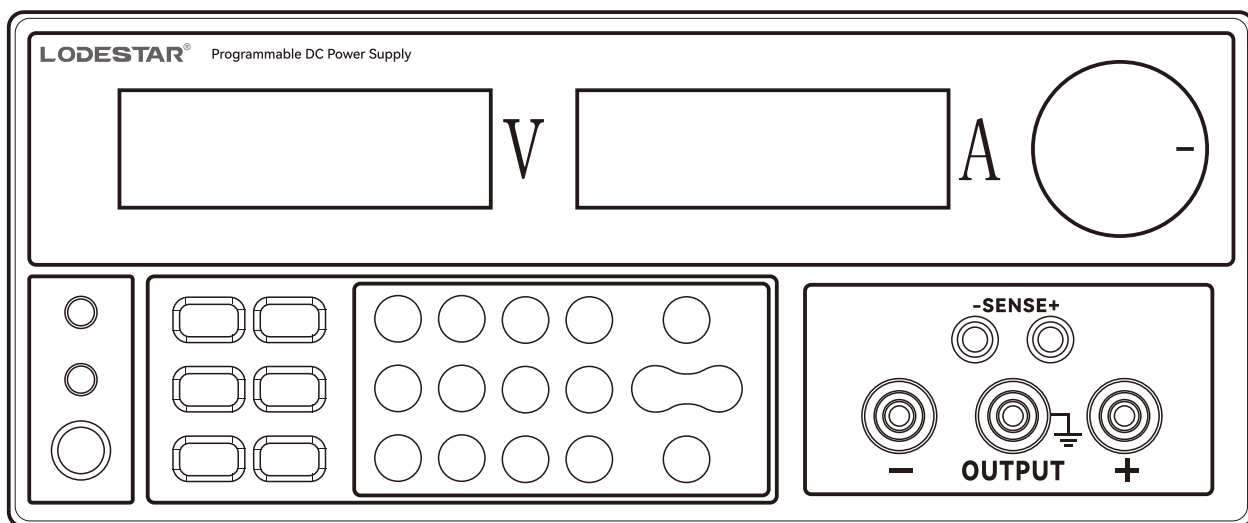

## 目录

|                                 |     |
|---------------------------------|-----|
| 安全概要 .....                      | III |
| 1. 产品说明 .....                   | 1   |
| 1.1 介绍 .....                    | 1   |
| 1.2 特性 .....                    | 1   |
| 1.3 前面板和后面板描述 .....             | 2   |
| 1.4 键盘描述 .....                  | 2   |
| 2. 操作说明 .....                   | 4   |
| 2.1 前面板操作说明 .....               | 4   |
| 2.2 输入方式 .....                  | 4   |
| 2.2.1 数字键输入 .....               | 4   |
| 2.2.2 旋钮输入 .....                | 4   |
| 2.3 输出电压设定 .....                | 4   |
| 2.4 输出电流设定 .....                | 4   |
| 2.5 过电压保护设定 .....               | 4   |
| 2.5.1 过电压保护值设定 .....            | 5   |
| 2.5.2 过电压保护功能开启/关闭 .....        | 5   |
| 2.6 过电流保护设定 .....               | 5   |
| 2.6.1 过电流保护值设定 .....            | 5   |
| 2.6.2 过电流保护状态设定 .....           | 5   |
| 2.7 输出延迟时间设定（本系列常规机该功能无效） ..... | 5   |
| 2.8 功能设定 .....                  | 6   |
| 2.8.1 功能恢复出厂设置 .....            | 6   |
| 2.8.2 输出状态记忆功能 .....            | 6   |
| 2.8.3 电压输入参数最大值限制 .....         | 6   |
| 2.8.4 电流输入参数最大值限制 .....         | 6   |
| 2.8.5 RS232 波特率设置 .....         | 6   |
| 2.8.6 蜂鸣器设置 .....               | 7   |
| 2.8.7 快速功能键设置 .....             | 7   |
| 2.8.8 电压自检功能设置 .....            | 7   |
| 2.8.9 通信地址设置 .....              | 7   |
| 2.8.10 远程感应功能设置 .....           | 7   |

|                        |    |
|------------------------|----|
| 2.8.11 通信协议选择 .....    | 7  |
| 2.8.12 缓启动设置 .....     | 8  |
| 2.8.13 编码器设置模式 .....   | 8  |
| 2.8.14 查看软件版本 .....    | 8  |
| 2.8.15 触发方式设置 .....    | 8  |
| 2.8.16 触发功能设置 .....    | 8  |
| 2.8.17 自动关闭时间设置 .....  | 8  |
| 2.8.18 电流偏移量 .....     | 9  |
| 2.8.19 线损补偿设置 .....    | 9  |
| 2.8.20 存储操作 .....      | 9  |
| 2.8.21 调取操作 .....      | 9  |
| 2.9 输出开关 .....         | 9  |
| 2.10 键盘锁功能 .....       | 9  |
| 2.11 调节旋钮 .....        | 9  |
| 2.12 保护功能 .....        | 9  |
| 2.13 操作模式说明 .....      | 10 |
| 2.13.1 恒压操作模式 .....    | 10 |
| 2.13.2 恒流操作模式 .....    | 10 |
| 2.13.3 恒压/恒流状态切换 ..... | 10 |
| 3. 远程控制 .....          | 11 |
| 3.1 接口设置 .....         | 11 |
| 3.1.1 界面 .....         | 11 |
| 3.1.2 通讯设定 .....       | 11 |
| 3.2 SCPI 编程指令集 .....   | 11 |
| 4. 维护 .....            | 12 |
| 4.1 定期检查 .....         | 12 |
| 4.2 保险丝的替换 .....       | 12 |
| 5. 产品规格 .....          | 13 |







技术指标若有变动恕不另作声明。

## 安全概要

这章节包含了电源供应器的操作，以及储存时必须遵照的重要安全指示。使用者在操作前请先仔细阅读以下指示，以确保安全并使机器保持在最佳状态。

### 安全符号

以下各种安全符号可能会出现在这本操作手册或是本产品上：

|  |    |           |                                 |
|--|----|-----------|---------------------------------|
|   | 警告 | <b>警告</b> | 警告性声明指出可能会危害操作人员生命安全的条件和行为      |
|   | 注意 | <b>注意</b> | 注意性声明指出可能会对本产品或连接到本产品的其他设备造成损坏。 |
|   |    | <b>危险</b> | 注意高电压                           |
|   |    |           | 保护接地端子                          |
|   |    |           | 接地（大地）端子                        |
|  |    |           | 壳体接地端                           |

### 安全指南

#### 一般介绍



注意

- 不要放置重物在机壳上。
- 避免严重撞击或不当的处置导致机器损坏。
- 连接仪器时需采取释放静电的预防措施。
- 不要阻塞侧板和后板的通风口。
- 除非是专业人员，请勿拆装机器。

#### 电源供应



警告

- AC 输入电压：220V±10%，50Hz（或 110V±10%，60Hz 手动切换）。
- 确保电源电缆的接地线连接到接地端，以避免电击。

#### 保险丝



警告

- 开机前确保使用正确的保险丝型号。
- 为防止火灾，只允许使用本产品指定规格的保险丝。
- 替换保险丝前先切断电源，排除造成保险丝损坏的原因。

#### 清洁机器

- 清洁前先切断电源。
- 使用温和的洗涤剂和清水沾湿柔软的布，不要直接喷洒清洁剂
- 不要使用化学或清洁剂含研磨的产品例如苯、甲苯、二甲苯和丙酮

#### 操作环境

- 使用地点：室内，避免直接日晒，灰尘以及强烈磁场的地方。
- 相对湿度：<80%
- 海拔：<2000m
- 温度：0℃ ~ 40℃

#### 存储环境

- 室内
- 相对湿度：<70%
- 温度：10℃ ~ 70℃

# 1. 产品说明

## 1.1 介绍

本系列产品是一款高精度单输出的可编程直流线性电源，轻便小巧，可调，多种操作模式。整个系统完全由微处理机（MPU）控制，可以轻易的利用通讯接口(RS-232) 与计算机 (PC) 联机，来满足使用者对自动测试及自动控制方面的需求。其软件指令完全符合SCPI 命令格式，方便使用者自行开发自动测试及自动控制应用程序。由于系统的全数字化，数据输入完全由键盘及旋钮控制，快速精确且方便。可以广泛用于电子产品开发、器件测试、通信行业、实验室和科研机构。

## 1.2 特性

- 小巧轻便，兼具桌上型和系统性的特性
- 双五位数码管显示电压电流，清晰明了
- 高分辨率与高精度
- 恒压/恒流自动切换
- 具有输出控制开关，控制更加灵活
- 方便且快速的操作与设定界面，高速调节旋钮和数字按键输入
- 内置蜂鸣器作为提示或警告
- 100 组设定储存与调出功能，可存储/调用 100 组电压电流等数据
- 远程感应实现补偿负载线的压降
- 过载，极性接反保护，过压保护，过流保护，过温度保护
- 一键锁定功能，有效防止误操作
- 温控风扇转速使仪器具有低噪声，风扇寿命更长久
- 配备 RS232 接口
- 支持 SCPI 和 MODBUS 编程指令集

### 1.3 前面板和后面板描述

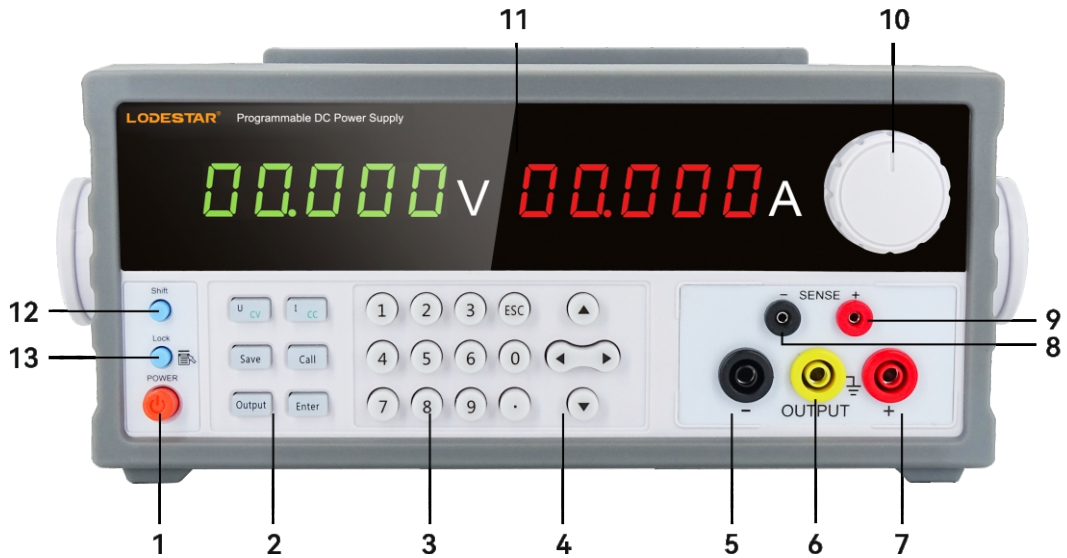

前面板图

|           |         |          |           |
|-----------|---------|----------|-----------|
| 1 电源开关    | 2 功能键   | 3 数字键    | 4 方向键     |
| 5 输出负     | 6 接地    | 7 输出正    | 8 远程感应端子负 |
| 9 远程感应端子正 | 10 调节旋钮 | 11 显示数码管 | 12 功能组合键  |
| 13 一键锁住键  |         |          |           |



后面板图

|                                     |                |                   |
|-------------------------------------|----------------|-------------------|
| 1 通信接口(标配 RS232, 可选配 RS485、USB、LAN) | 2. 航空控制接口功能可订制 | 3 BNC 接口外部触发接口可订制 |
| 4. 电源风扇                             | 5. 电源插座 含保险丝座  | 6. 壳体接地端子         |

### 1.4 键盘描述

#### 按键说明

前面板上共有 24 个按键 不含 POWER 键 ， 键上方的字表示该键的基本功能，直接按键执行基本功

能。键下方的字表示该键的上档功能，首先按【Shift】键，再按某一键执行该键的上档功能。按键按下后，会用响声“嘀”来提示（蜂鸣器设置开）。

| 键名     | 主功能     | 上档功能 | 键名    | 主功能    | 上档功能 |
|--------|---------|------|-------|--------|------|
| 0      | 输入数字 0  | 未订制  | 7     | 输入数字 7 | 未订制  |
| 1      | 输入数字 1  | 未订制  | 8     | 输入数字 8 | 未订制  |
| 2      | 输入数字 2  | 未订制  | 9     | 输入数字 9 | 未订制  |
| 3      | 输入数字 3  | 未订制  | .     | 输入小数点  | 未订制  |
| 4      | 输入数字 4  | 未订制  | ⊕、∅   | 光标左、右移 | 无    |
| 5      | 输入数字 5  | 未订制  | ∩、∪   | 上下翻页   | 无    |
| 6      | 输入数字 6  | 未订制  | Enter | 确认键    | 无    |
| U      | 设定电压    | 未订制  | I     | 设定电流   | 未订制  |
| Save   | 保存      | 未订制  | Call  | 调取     | 未订制  |
| Output | 输出开启或关闭 | 无    | Lock  | 按键锁定   | Menu |
| Shift  | 上档功能选择键 | 无    | Esc   | 取消键    | 无    |

## 2. 操作说明

### 2.1 前面板操作说明

- (1) 本仪器及使用手册中所出现的电压和电流的单位，均采用伏特 V 及安培 A。
- (2) 本仪器出厂设定为前面板操作模式，当电源开启后，即可在面板上进行所需求的仪器设定。

### 2.2 输入方式

#### 2.2.1 数字键输入

利用 0~9，数字键输入要设定的值，再按【Enter】键确认即可。如果数据输入有错，按【Esc】键清除当前数据，然后再重新输入数据。

#### 2.2.2 旋钮输入

实际应用中，有时需要对信号进行连续调节，这时可以使用数字调节旋钮。按移位键【⊕】或【⊖】，可以使光标指示位左移或右移，面板上的旋钮为数字调节旋钮，向右转动旋钮，可使光标指示位的数字连续加一，并能向高位进位。向左转动旋钮，可使光标指示位的数字连续减 1，并能向高位借位。使用旋钮输入数据时，数字改变后即刻生效。

### 2.3 输出电压设定

按【U】键，电压显示窗口闪烁。

方式 1：按 0~9，数字键再按【Enter】键设定输出电压。

方式 2：利用【⊕】或【⊖】键移动光标到指定的位，旋转旋钮调节电压设定值。

例如：设定输出电压为 32.000V。

按【U】【3】【2】【.】【0】【0】【0】【Enter】，数码管显示输入电压值。

### 2.4 输出电流设定

按【I】键，电流显示窗口闪烁。

方式 1：按 0~9，数字键再按【Enter】键设定输出电压。

方式 2：利用【⊕】或【⊖】键移动光标到指定的位，旋转旋钮调节电压设定值。

例如：设定输出电压为 10.000A。

按【I】【1】【0】【.】【0】【0】【0】【Enter】，数码管显示输入电流值。

### 2.5 过电压保护设定

过电压保护是保护电源供应器和 DUT 在超出设定电压时获得保护。操作前先打开过压保护功能，设定过压保护值，当输出端电压超过这个限制时，输出立刻关闭，数码管面板上“OVP”。且电压调节大小受限与该保护值。

应避免加载于输出端的外部电压超过额定电压的 120%，否则产品内部器件会损坏!

当电源处于过电压保护状态后，需检查外部原因,当外部因素消除之后,通过 ON/OFF 按键,方可重新打开。

### 2.5.1 过电压保护值设定

按上【↶】下【⏏】翻页进入运行参数菜单，翻页至【OVP-S.】，即可修改保护阈值。

方式 1：按 0~9，.数字键再按【Enter】键设定过电压保护值。

方式 2：利用【⊕】或【⊖】键移动光标到指定的位，旋转旋钮调节过压保护设定值。

例如：设定过电压保护电压值为 33.0V。

按上【↶】下【⏏】翻页直至进入【OVP-S】【3】【3】【.】【0】【Enter】。

### 2.5.2 过电压保护功能开启/关闭

按上【↶】下【⏏】翻页进入运行参数菜单，翻页至【OVP-E.】，即可修改保护功能状态：ON/OFF。

## 2.6 过电流保护设定

过电流保护是保护电源供应器的负载电流在超出设定电流时获得保护。操作前先打开过流保护功能，设定过流保护值，当负载电流超过这个限制时，输出立刻关闭，面板上数码管显示“OCP”。且电流调节大小受限与该保护值。

### 2.6.1 过电流保护值设定

按上【↶】下【⏏】翻页进入运行参数菜单，翻页至【OCP-S.】，即可修改保护阈值。

方式 1：按 0~9，.数字键再按【Enter】键设定过电流保护值。

方式 2：利用【⊕】或【⊖】键移动光标到指定的位，旋转旋钮调节过流保护设定值。

例如：设定过电压保护电压值为 11.0A。

按上【↶】下【⏏】翻页直至进入【OCP-S】【1】【1】【.】【0】【Enter】。

### 2.6.2 过电流保护状态设定

按上【↶】下【⏏】翻页进入运行参数菜单，翻页至【OCP-E.】，即可修改保护功能状态：ON/OFF。

## 2.7 输出延迟时间设定（本系列常规机该功能无效）

按下【Shift】,再按【Lock】后，按上【↶】下【⏏】翻页进入运行参数菜单，翻页至【DELAY】，即可修改延时参数。

注：此Delay设定仅当自动循环执行时才有作用，所以当记忆存储时，此Delay设定会同时储存于记忆位置中。

## 2.8 功能设定

按下【Shift】,再按【Lock】后,按上【↶】下【↷】翻页,选中相应菜单项目。按【↷】翻页,对应第1个菜单是INIT,表示恢复出厂设置;第2个是OUT,表示输出状态;第3个是V-M,表示电压输入最大值;第4个是I-M,表示电流输入最大值;第5个BAUD,表示通信波特率;第6个BEEP,表示提示音,第7个H.K.;表示快捷键,第8个V.SELF;表示电压自动微调;第9个ADDR,表示通信地址;第10个SENSE,表示补偿功能;第11个COM-P,表示通信协议;第12个SL-ON,表示缓启动;第13个EC-,表示编码器设置;第14个VER,表示版本号;第15个T-S,表示触发方式;第16个T-F,表示触发功能;第17个A-OFF,表示自动闭关时间;第18个T-DAT,表示电流偏移量;第19个WL-MR,表示线损补偿。

### 2.8.1 功能恢复出厂设置

按【Shift】,再按【Lock】后进入MENU按上【↶】下【↷】翻页,显示“INIT”,利用【↶】【↷】键或旋钮来选择开启。此功能开启后,将会跳出MENU界面,所有设定的功能恢复出厂设置。

### 2.8.2 输出状态记忆功能

按【Shift】,再按【Lock】后进入MENU按上【↶】下【↷】翻页,显示“OUT”,利用【↶】【↷】键或旋钮来选择功能。

功能项:0-F.DF 表示开机不输出,且恢复默认参数(5V 1A);

1-F.ST 表示开机不输出,且恢复用户设置参数;

2-O.ST 表示开机输出,且恢复用户设置参数。

### 2.8.3 电压输入参数最大值限制

按【Shift】,再按【Lock】后进入MENU按上【↶】下【↷】翻页,显示“V-M”,利用数字键盘或旋钮设置参数。

该功能设置的参数将限制【U-CV】或通信进行电压设置的最大值。

如:U Max 参数设置为15V,那么【U-CV】或通信命令设置电压时,将被限制为最大15V。

### 2.8.4 电流输入参数最大值限制

按【Shift】,再按【Lock】后进入MENU按上【↶】下【↷】翻页,显示“I-M”,说明参考“V-M”。

### 2.8.5 RS232 波特率设置

按【Shift】,再按【Lock】后进入MENU按上【↶】下【↷】翻页直到显示“BAUD”,用旋钮设定波特率对应的代码,使设备符合计算机远程控制时波特率的要求。

下表为波特率对应的代码表:

|     |      |      |      |      |       |       |       |        |
|-----|------|------|------|------|-------|-------|-------|--------|
| 代码  | 1.2K | 2.4k | 4.8K | 9.6K | 19.2K | 38.4K | 57.6K | 11.52K |
| 波特率 | 1200 | 2400 | 4800 | 9600 | 19200 | 38400 | 57600 | 115200 |

## 2.8.6 蜂鸣器设置

按【Shift】，再按【Lock】后，按上【↶】下【↷】翻页，选中相应菜单项目。

## 2.8.7 快速功能键设置

按【Shift】，再按【Lock】后，按上【↶】下【↷】翻页，显示“H.K.”，利用【↶】【↷】键或旋钮来选择开启或关闭。此功能开启后，只要按0~9数字键就可以调用出存储器中对应的第0~9组的设定。

## 2.8.8 电压自检功能设置

按【Shift】，再按【Lock】后，按上【↶】下【↷】翻页，显示“V.SELF”，利用【↶】【↷】键或旋钮来选择开启或关闭。

此功能开启后，自动监测输出端电压值，调节输出，减少与设定电压值间的偏差。

## 2.8.9 通信地址设置

按【Shift】，再按【Lock】后，按上【↶】下【↷】翻页，显示“ADDR”，利用【↶】【↷】键、旋钮或者数字键可以设置需要的地址。

注：地址设置范围为1~250。

## 2.8.10 远程感应功能设置

当负载消耗较大电流的时候，就会在电源到负载端子的连接线上产生压降。在恒压状态下，远程感应可以自动补偿负载线的压降。

在使用远端感应功能前，你必须要先设定电源为远端感应模式，且须在输出关闭时才可以开启远程感应功能。Sense引线尽量采用双绞线，且最好不要与负载线绞在一起。

按下【Shift】，再按【Lock】后，按上【↶】下【↷】翻页，选中相应菜单SENSE，利用【↶】【↷】键或旋钮来选择开启或关闭。

电源远端量测的接线示意图：

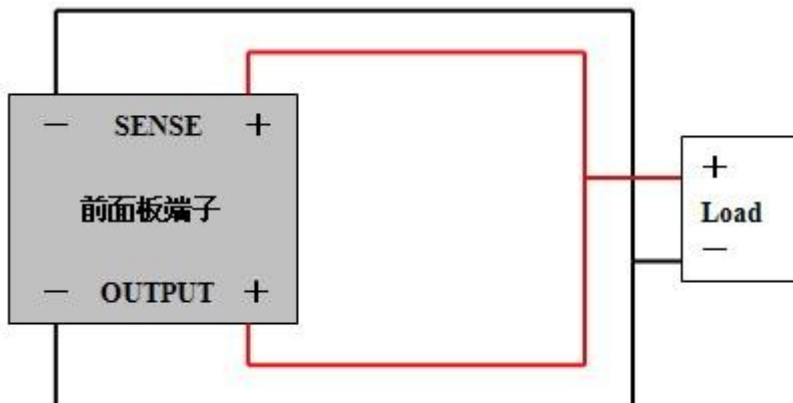

## 2.8.11 通信协议选择

按下【Shift】,再按【Lock】后,按上【↶】下【↷】翻页,显示“COM-P”,利用【↶】【↷】键或旋钮来选择 SCPI 或者 Modbus 协议。

- 功能项: OFF 表示关闭缓启动功能;
- CV 表示恒压模式下增大电压的上升时间;
- CC 表示恒流模式下增大电流的上升时间。

### 2.8.12 缓启动设置

按下【Shift】,再按【Lock】后,按上【↶】下【↷】翻页,显示“SL-ON”,利用【↶】【↷】键或旋钮来选择功能。

### 2.8.13 编码器设置模式

按下【Shift】,再按【Lock】后,按上【↶】下【↷】翻页,显示“EC-”,利用【↶】【↷】键或旋钮来选择功能。

- 功能项: O.N 表示关闭编码器设置功能;
- 1.S U 表示无需按【V-set】,可以直接通过旋转编码器调节电压的大小;
- 2.S I 表示无需按【I-set】,可以直接通过旋转编码器调节电流的大小。

### 2.8.14 查看软件版本

按下【Shift】,再按【Lock】后,按上【↶】下【↷】翻页,选中相应菜单“VER”。

### 2.8.15 触发方式设置

按下【Shift】,再按【Lock】后,按上【↶】下【↷】翻页,显示“T-S”,利用【↶】【↷】键或旋钮来选择功能。

- 功能项: 0-IMM 表示通讯指令触发;
- 1-EXT 表示外部触发;
- 2-PUL 表示脉冲触发;
- 3-LEL 表示低电平触发。

### 2.8.16 触发功能设置

按下【Shift】,再按【Lock】后,按上【↶】下【↷】翻页,显示“T-F”,利用【↶】【↷】键或旋钮来选择功能。

0-Out 表示每来一次触发,输出开关的状态就改变一次,如果原来是开启的,那么来了一次触发后就会关闭,反之亦然;

### 2.8.17 自动关闭时间设置

按下【Shift】,再按【Lock】后,按上【↶】下【↷】翻页,显示“A-OFF”,利用数字键盘或旋钮设置参数。

此功能可以实现 0~99999s 定时输出,当输出达到设定时间,将会自动关闭输出。

### 2.8.18 电流偏移量

按下【Shift】,再按【Lock】后,按上【↶】下【↷】翻页,显示“T-DAT”,可以查看到空载输出时电流的偏移量。

该功能在空载输出条件,如果电流输出显示不为零,按【Shift】+【Esc】可清除电流偏移量,并保存到“T-DAT”内。

### 2.8.19 线损补偿设置

按下【Shift】,再按【Lock】后,按上【↶】下【↷】翻页,显示“WL-mR”,利用【↶】【↷】键、旋钮或者数字键盘设置线阻值(mR)。

### 2.8.20 存储操作

电源可以把一些常用的参数分别保存在100组非易失性存储器中,供用户方便、快速的取出使用。存储内容包含输出电压值、输出电流值、过电压保护值、过电流保护值、过电压保护状态、过电流保护状态、延迟时间。

按【Save】键,旋钮设定组号,按【Enter】ENTER,保存当前运行参数

例如:存储设定到内存地址为5。

按【Save】【5】【Enter】。

### 2.8.21 调取操作

按【Call】键,旋钮设定组号,按【Enter】,调取该组运行参数

例如:调用设定,内存地址为5。

按【Call】【5】【Enter】。

## 2.9 输出开关

前面板的【On/off】键控制输出的开启与关闭。

## 2.10 键盘锁功能

前面板的【Lock】键可开启/关闭键盘锁功能,按【Lock】键后,这时按其它按键,数码管会显示“-L-L-L-L”,除【Lock】键和【On/off】键外,其他按键和旋钮均被锁定。

## 2.11 调节旋钮

按下调节旋钮,则可以切换光标位置。

## 2.12 保护功能

本仪器提供有过电压,过电流,过温保护功能。

过温度（OTP）保护功能。当操作本仪器时，产生了异常的高温时本仪器会自动将输出关闭，以保障用户生命及仪器的安全使用。

## 2.13 操作模式说明

### 2.13.1 恒压操作模式

(1) 连接负载到输出端

为了使用上的安全，请在关闭输出的情况下，连接负载到输出的(+)与(-)端子。

(2) 输入欲设定的电流限定值

按下【I】，进入电流设定值输入模式。在此输入模式下，可使用数字键盘或旋钮输入，设定完成欲变更的电流设定值。

(3) 输入欲输出的电压值

按下【U】，进入电压设定值输入模式。在此输入模式下，可使用数字键盘或旋钮输入，设定完成欲变更的电压设定值。

(4) 启动输出

按下【On/Off】后，输出开启，此刻显示为实际输出测量值。

(5) 确认本电源供应器处于恒压模式

请确认 CV 灯是否亮起，以确保输出操作于恒压操作模式。若 CC 灯亮起，则需加大其电流限定值，以确保输出操作于恒压操作模式。

### 2.13.2 恒流操作模式

(1) 连接负载到输出端

为了使用上的安全，请在关闭输出的情况下，连接负载到输出的(+)与(-)端子。

(2) 输入欲设定的电压限定值

按下【U】，进入电压设定值输入模式，在此输入模式下可使用数字键盘或旋钮输入，设定完成欲变更的电压设定值。

(3) 输入欲输出的电流值

按下【I】，进入电流设定值输入模式，在此输入模式下可使用数字键盘或旋钮输入，设定完成欲变更的电流设定值。

(4) 启动输出

按下【On/Off】后，输出开启，此刻显示屏显示为实际输出测量值。

(5) 确认本电源供应器处于恒流模式

请确认 CC 灯是否亮起，以确保输出操作于恒流操作模式。若 CV 灯亮起，则需加大其电压限定值，以确保输出操作于恒流操作模式。

### 2.13.3 恒压/恒流状态切换

在输出状态下，当输出电流小于电流设定值时，电源供应器处于恒压状态，则恒压指示灯亮绿色，输出电压稳定在设定值，直到输出电流达到电流设定值时，进入恒流状态，恒流指示灯亮红色，电源根据负载不同在恒流恒压状态间自动切换。

### 3. 远程控制

该系列电源均支持远程控制模式，提供了 RS232 接口或者 USB 接口与计算机进行通讯，并通过上位机软件实现面板上所有功能。

#### 3.1 接口设置

##### 3.1.1 界面

可在仪器的后面板安装有RS232、RS485、USB、LAN接口，如下图所示。

|   |   |   |   |
|---|---|---|---|
|  |  |  |  |
| RS232接口   | RS 485接口  | USB接口   | 网口  |

##### 3.1.2 通讯设定

根据以下设定 PC 机里的 COM 口

- (1) 波特率：9600
- (2) 校验位：None
- (3) 数据位：8
- (4) 停止位：1
- (5) 数据流出控制：None

**注1：**如果远程控制时电源没有响应，请检查：

- 接口线自身是否断开。
- 接口线、电源与 PC 对应引脚的连接是否正确。
- 接口线连接是否紧固。
- 远程控制程序的通信参数设置与 3.1.2 是否一致。
- 远程控制程序的命令结束符是否为换行（16 进制 0X0A）。

#### 3.2 SCPI 编程指令集

详细SCPI编程指令集请参考编程手册。

## 4. 维护

### 4.1 定期检查

- 在产品使用过程中，为保证产品能够达到其最佳工作状态，请做定期检查。
- 检查电源供应器电源输入插座是否被烧坏。检查电源输出端子是否有松动。

### 4.2 保险丝的替换

步骤： (1) 拿走电源线，然后用小螺丝刀取走保险丝盒。

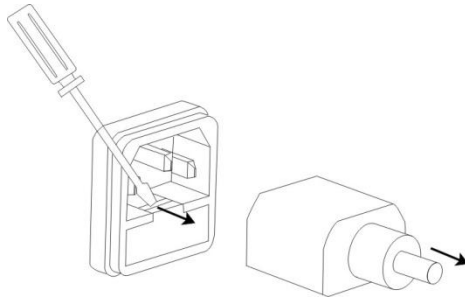

(2) 替换保险丝。

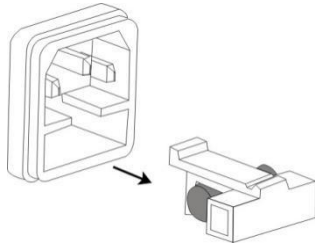

保险丝规格：

T10AL/250V

## 5. 产品规格

使用此规格时，请确保开机 30 分钟以上。表一：

| 型号                     | 30V3A  | 30V5A   | 30V10A  | 60V3A   | 60V5A   |
|------------------------|--|---------|---------|---------|---------|
| <b>额定直流输出 (0℃~40℃)</b> |  |         |         |         |         |
| 电压                     | 0~30V  | 0~30V   | 0~30V   | 0~60V   | 0~60V   |
| 电流                     | 0~3A   | 0~5A    | 0~10A   | 0~3A    | 0~5A    |
| 过压保护                   | 0.1~33V  | 0.1~33V | 0.1~33V | 0.1~65V | 0.1~65V |
| 过流保护                   | 0.1~4A   | 0.1~6A  | 0.1~11A | 0.1~4A  | 0.1~6A  |
| <b>电压输出</b>            |  |         |         |         |         |
| 电源效应                   | ≤0.01%+3mV   |         |         |         |         |
| 负载效应                   | ≤0.01%+3mV(I≤3A)/≤0.01%+5mV(I>3A)  |         |         |         |         |
| 恢复时间                   | ≤100us(50% load change, minimum load 0.5A)                               |         |         |         |         |
| 涟波和噪声                  | ≤1mV rms(I≤3A)(5Hz~1MHz)/≤2mV rms(I>3A)(5Hz~1MHz)                        |         |         |         |         |
| 温度系数                   | ≤100ppm/℃  |         |         |         |         |
| 设定精度                   | ±(0.03% of reading + 10mV)(25±5℃)  |         |         |         |         |
| 设定分辨率                  | 1mV(5 位)/0.1mV(6 位)  |         |         |         |         |
| <b>电流输出</b>            |  |         |         |         |         |
| 电源效应                   | ≤0.01%+3mA   |         |         |         |         |
| 负载效应                   | ≤0.01%+3mA(I≤3A)/≤0.01%+5mA(I>3A)  |         |         |         |         |
| 涟波和噪声                  | ≤3mA rms(I≤3A)/≤6mA rms(I>3A)  |         |         |         |         |
| 设定精度                   | ±(0.02% of reading + 0.1% of FS) (25±5℃)                                 |         |         |         |         |
| 设定分辨率                  | 0.1mA(10A 以上分辨率 1mA)(5 位);0.01mA(10A 以上分辨率 0.1mA)(6 位)                   |         |         |         |         |
| <b>显示</b>              |  |         |         |         |         |
| 电压                     | 5 digits display/6 digits display  |         |         |         |         |
| 电流                     | 5 digits display/6 digits display  |         |         |         |         |
| 电压分辨率                  | 1mV(5 位)/0.1mV(6 位)  |         |         |         |         |
| 电流分辨率                  | 0.1mA(10A 以上分辨率 1mA)(5 位);0.01mA(10A 以上分辨率 0.1mA)(6 位)                   |         |         |         |         |
| 读数精度                   | ±(0.02% of reading+5mV)(25±5℃); ±(0.02% of reading + 0.1% of FS) (25±5℃) |         |         |         |         |
| 保护                     | 过载保护, 极性接反保护, 过压保护, 过流保护, 过温保护   |         |         |         |         |
| 锁键盘                    | 有  |         |         |         |         |
| 编程接口                   | RS232,485(选配),航空报警接口(选配),模拟控制接口(选配),LAN 接口(选配)                           |         |         |         |         |
| 编程协议                   | 兼容 Modbus、SCPI 协议  |         |         |         |         |
| 存储调出                   | 100 组存储, 包含 10 组快捷参数存储   |         |         |         |         |
| 绝缘度                    | 输出端子与机壳或其它端子间; ≤60VDC  |         |         |         |         |
| 操作环境                   | 室内使用 海拔: ≤2000m 环境温度: 0℃~40℃ 相对湿度: ≤80%<br>安装等级: II 污染程度: 2              |         |         |         |         |
| 储存环境                   | 环境温度: -10~70℃ 相对湿度: ≤70%   |         |         |         |         |
| 电源输入                   | AC220V±10%,50/60Hz   |         |         |         |         |
| 附件                     | 电源线 1 根,上位机软件光盘 1 张,RS232 接口电缆 1 根,USB 通信电缆 1 根                          |         |         |         |         |
| 尺寸 (去保护套)              | 376(D)×215(W)×89(H)mm  |         |         |         |         |
| 重量                     | 约 7kg, 各型号不一样  |         |         |         |         |

表二:

| 型号                     | 150V1A   | 150V2A   | 150V3A   | 250V1A   |
|------------------------|--|----------|----------|----------|
| <b>额定直流输出 (0℃~40℃)</b> |  |          |          |          |
| 电压                     | 0~150V   | 0~150V   | 0~150V   | 0~250V   |
| 电流                     | 0~1A   | 0~2A     | 0~3A     | 0~1A     |
| 过压保护                   | 0.1~153V   | 0.1~153V | 0.1~153V | 0.1~253V |
| 过流保护                   | 0.1~1.5A   | 0.1~2.5A | 0.1~3.5A | 0.1~1.2A |
| <b>电压输出</b>            |  |          |          |          |
| 电源效应                   | ≤0.01%+3mV   |          |          |          |
| 负载效应                   | ≤0.01%+3mV(I≤3A)/≤0.01%+5mV(I>3A)  |          |          |          |
| 恢复时间                   | ≤100us(50% load change, minimum load 0.5A)                               |          |          |          |
| 涟波和噪声                  | ≤1mV rms(I≤3A)(5Hz~1MHz)/≤2mV rms(I>3A)(5Hz~1MHz)                        |          |          |          |
| 温度系数                   | ≤100ppm/℃  |          |          |          |
| 设定精度                   | ±(0.03% of reading + 10mV)(25±5℃)  |          |          |          |
| 设定分辨率                  | 1mV(5位);0.1mV(6位)  |          |          |          |
| <b>电流输出</b>            |  |          |          |          |
| 电源效应                   | ≤0.01%+3mA   |          |          |          |
| 负载效应                   | ≤0.01%+3mA(I≤3A)/≤0.01%+5mA(I>3A)  |          |          |          |
| 涟波和噪声                  | ≤3mA rms(I≤3A)/≤6mA rms(I>3A)  |          |          |          |
| 设定精度                   | ±(0.02% of reading + 0.1% of FS) (25±5℃)                                 |          |          |          |
| 设定分辨率                  | 0.1mA(5位);0.01mA(6位)   |          |          |          |
| <b>显示</b>              |  |          |          |          |
| 电压                     | 5 digits display/6 digits display  |          |          |          |
| 电流                     | 5 digits display/6 digits display  |          |          |          |
| 电压分辨率                  | 1mV(5位);0.1mV(6位)  |          |          |          |
| 电流分辨率                  | 0.1mA(5位);0.01mA(6位)   |          |          |          |
| 读数精度                   | ±(0.02% of reading+5mV)(25±5℃); ±(0.02% of reading + 0.1% of FS) (25±5℃) |          |          |          |
| 保护                     | 过载保护, 极性接反保护, 过压保护, 过流保护, 过温保护   |          |          |          |
| 锁键盘                    | 有  |          |          |          |
| 编程接口                   | RS232, 485(选配), 航空报警接口(选配), 模拟控制接口(选配), LAN 接口 (选配)                      |          |          |          |
| 编程协议                   | 兼容 Modbus、SCPI 协议  |          |          |          |
| 存储调出                   | 100 组存储, 包含 10 组快捷参数存储   |          |          |          |
| 绝缘度                    | 输出端子与机壳或其它端子间; ≤60VDC  |          |          |          |
| 操作环境                   | 室内使用 海拔: ≤2000m 环境温度: 0℃~40℃ 相对湿度: ≤80%<br>安装等级: II 污染程度: 2              |          |          |          |
| 储存环境                   | 环境温度: -10~70℃ 相对湿度: ≤70%   |          |          |          |
| 电源输入                   | AC220V±10%,50/60Hz   |          |          |          |
| 附件                     | 电源线 1 根, 上位机软件光盘 1 张, RS232 接口电缆 1 根, USB 通信电缆 1 根                       |          |          |          |
| 尺寸(去保护套)               | 376(D)×215(W)×89(H)mm  |          |          |          |
| 重量                     | 约 7kg, 各型号不一样  |          |          |          |

# LPA Series Programmable Wide Range Linear Power Supply User Manual

This manual is applicable to the following models in this series:  
**LPA1501 / LPA2002 / LPA3001 / LPA3005 / LPA6003 / LPA6005**

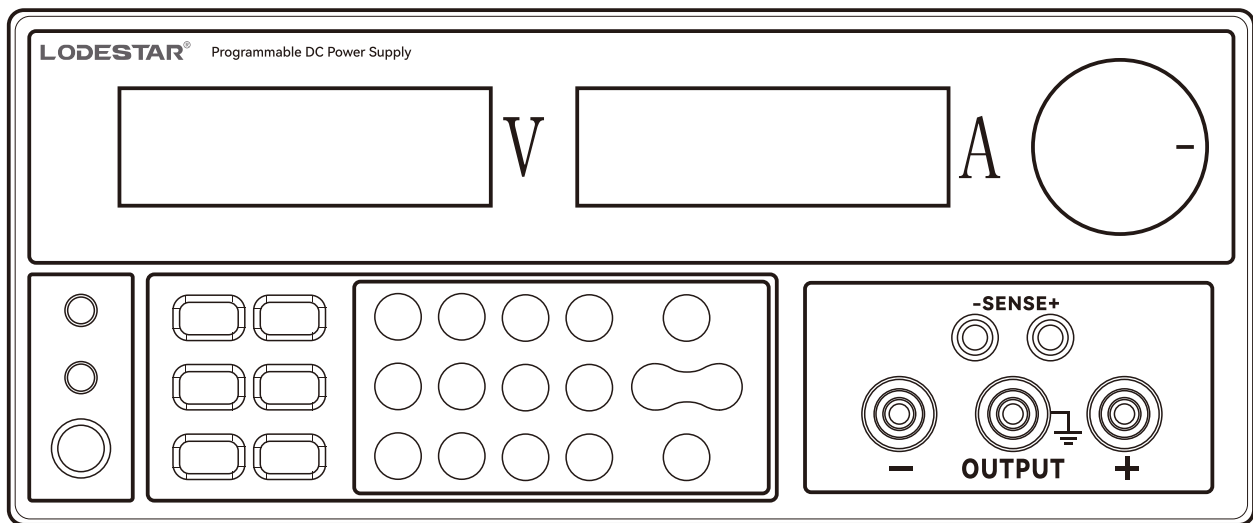

## Catalogue

|   |     |
|---|-----|
| Security Summary.....   | III |
| 1. Product description .....  | 1   |
| 1.1 Introduce .....   | 1   |
| 1.2 Characteristic.....   | 1   |
| 1.3 Front panel and back panel .....  | 2   |
| 1.4 Keyboard.....   | 2   |
| 2. Operation declaration .....  | 4   |
| 2.1 Previous panel operation instructions.....  | 4   |
| 2.2 Parameter input .....   | 4   |
| 2.2.1 Input through numeric keypad.....   | 4   |
| 2.2.2 Input through knob .....  | 4   |
| 2.3 Output voltage setting.....   | 4   |
| 2.4 Output current setting .....  | 4   |
| 2.5 Overvoltage protection setting.....   | 4   |
| 2.5.1 Overvoltage protection value setting.....   | 5   |
| 2.5.2 Overvoltage protection status setting .....   | 5   |
| 2.6 Overcurrent protection setting.....   | 5   |
| 2.6.1 Overcurrent protection value setting.....   | 5   |
| 2.6.2 Overcurrent protection status setting.....  | 5   |
| 2.7 Output delay time setting (this function is invalid in this series of conventional machines)..... | 5   |
| 2.8 Function Settings.....  | 6   |
| 2.8.1 Function Restore factory Setting .....  | 6   |
| 2.8.2 Output state memory function.....   | 6   |
| 2.8.3 Maximum input voltage limit .....   | 6   |
| 2.8.4 Maximum input current limit.....  | 6   |
| 2.8.5 RS232 port baud rate setting .....  | 6   |
| 2.8.6 Beeper Setting .....  | 7   |
| 2.8.7 Hotkey Setting .....  | 7   |
| 2.8.8 Voltage self-test function setting.....   | 7   |
| 2.8.9 Communication address setting.....  | 7   |
| 2.8.10 Remote sensing function setting.....   | 7   |

|        |   |    |
|--------|---|----|
| 2.8.11 | Communication protocol selection.....         | 7  |
| 2.8.12 | Slow startup Settings.....                    | 8  |
| 2.8.13 | Encoder setup mode.....                       | 8  |
| 2.8.14 | View software version.....                    | 8  |
| 2.8.15 | Trigger setting .....                         | 8  |
| 2.8.16 | Trigger function Setting .....                | 8  |
| 2.8.17 | Scheduled Output Shutdown Setting .....       | 8  |
| 2.8.18 | Current offset.....                           | 9  |
| 2.8.19 | Line loss compensation setting.....           | 9  |
| 2.8.20 | Store operation .....                         | 9  |
| 2.8.21 | Retrieval operation .....                     | 9  |
| 2.9    | Out switch .....                              | 9  |
| 2.10   | Lock function .....                           | 9  |
| 2.11   | Adjustment knob .....                         | 9  |
| 2.12   | Protection function .....                     | 9  |
| 2.13   | Operation mode description.....               | 10 |
| 2.13.1 | Constant pressure operation mode.....         | 10 |
| 2.13.2 | Constant current operation mode.....          | 10 |
| 2.13.3 | Constant voltage/current state switching..... | 10 |
| 3.     | Telecontrol .....                             | 11 |
| 3.1    | Interface Setting .....                       | 11 |
| 3.1.1  | Interface .....                               | 11 |
| 3.1.2  | Communication Settings.....                   | 11 |
| 3.2    | SCPI programming instruction setting .....    | 11 |
| 4.     | Maintenance .....                             | 12 |
| 4.1    | Periodic inspection .....                     | 12 |
| 4.2    | Replacement of fuse.....                      | 12 |
| 5.     | Product specification .....                   | 13 |







**No further notice will be given if the technical specifications are changed.**

## Security Summary

This chapter contains the operation of the power supply and important safety instructions that must be followed when storing it, users should read the following instructions in detail before operating to ensure safety and keep the machine in optimal condition.

### Safety symbols

The following safety symbols may appear in this operating manual or on the product:

|  |                  |  |
|--|------------------|--|
|   | <b>Warning</b>   | The warning statement points out the conditions and behaviors that may endanger the life of the operator |
|   | <b>Attention</b> | The notice states that damage may occur to the product or other devices connected to the product.        |
|   | <b>Danger</b>    | Be careful with high voltage   |
|   |                  | Protect grounding terminals  |
|   |                  | Ground terminal  |
|  |                  | Shell grounding end  |

### Safety Guide

General Introduction

- Do not place heavy objects on the housing.
- Avoid serious impact or improper handling resulting in machine damage.
- Preventive measures against static electricity should be taken when connecting instruments.
- Do not block the ventilation ports of the side and rear panels.
- Do not disassemble the machine unless you are a professional.

power supply

- AC input voltage: 200-240VAC, 50/60Hz.
- Ensure that the power cable is connected to the grounding end to avoid electric shock.

fuse

- Make sure you use the correct fuse model before turning on the machine.
- In order to prevent fire, only the fuse of the specified specification of this product is allowed to be used.
- Cut off the power supply before replacing the fuse to eliminate the cause of the fuse damage.

Cleaning machines

- Cut off the power before cleaning.
- Use a mild detergent and water to moisten the soft cloth, do not spray cleaner directly
- Do not use chemical or cleaning products containing abrasives such as benzene, toluene, xylene and acetone

operational environment

- Where to use: indoors, away from direct sunlight, dust and strong magnetic fields.
- Relative humidity: <80%
- Altitude: <2000m
- Temperature: 0°C~40°C

Storage environment

- Indoor
- Relative humidity: <70%
- Temperature: 10°C~70°C

# 1. Product Description

## 1.1 Introduce

This series of products is a high-precision single-output programmable DC switched-mode power supply, featuring compact design, adjustable parameters, and multiple operational modes. The entire system is fully controlled by a microprocessor (MP), enabling seamless connectivity with computers (PC) through RS-232 communication interfaces to meet users' needs for automated testing and control systems. Its software commands fully comply with SCPI protocol standards, facilitating user development of custom automation applications. With full digitalization, data input is entirely managed via keyboard and rotary controls, ensuring rapid, precise, and user-friendly operation. The system finds wide application in electronic product development, component testing, telecommunications industries, laboratories, and research institutions.

## 1.2 Characteristic

- Compact and lightweight, combining the features of both desktop and system-level devices
- The dual five-digit digital tube displays the voltage and current clearly
- High resolution and high accuracy
- Constant voltage/current automatic switching
- With output control switch, control is more flexible
- Convenient and fast operation and setting interface, high speed adjustment knob and digital key input
- Built-in buzzer as a prompt or warning
- 100 sets of preset storage and retrieval functions can store/retrieve 100 sets of voltage, current and other data. Combined with the List to execute the program, simple automatic test purposes can be achieved
- Remote sensing achieves compensation for voltage drop across the connection wires between the output terminals and both ends of the load.
- Overload, polarity reversal protection, overvoltage protection, overcurrent protection, overtemperature protection
- One-click lock function, effectively prevent misoperation
- The temperature control fan speed makes the instrument have low noise, the fan life is longer
- Equipped with RS232 interface
- The programming instruction set supports SCPI and MODBUS

### 1.3 Front Panel and Back Panel

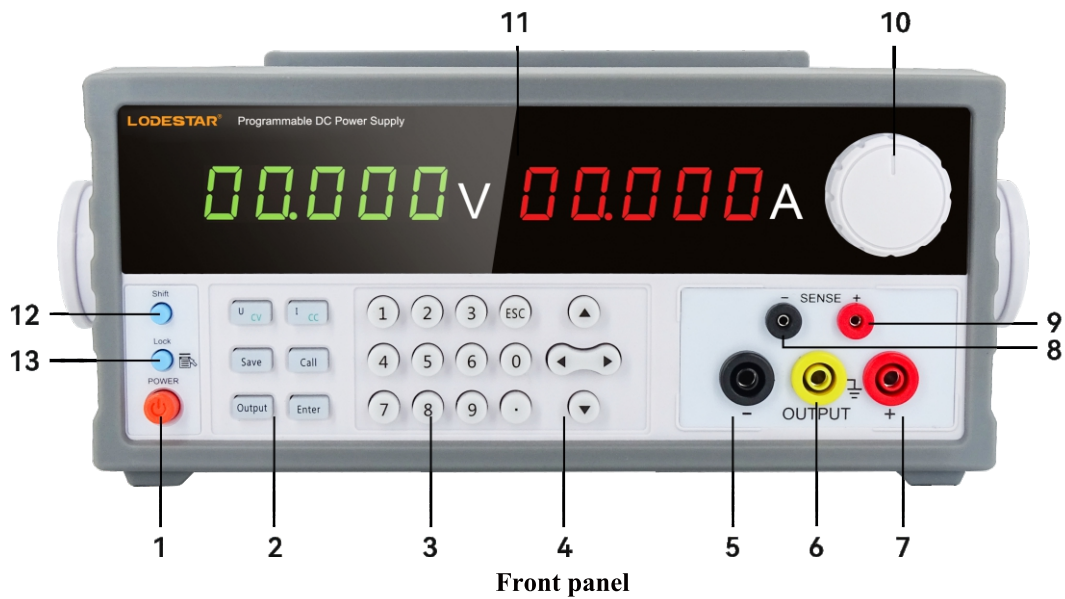

|                                    |                    |                            |                                    |
|------------------------------------|--------------------|----------------------------|------------------------------------|
| 1.Power switch                     | 2.Function key     | 3.Numbering key            | 4.Direction key                    |
| 5.Negative terminal                | 6.Ground           | 7.Positive terminal        | 8.Remote sensing negative terminal |
| 9.Remote sensing positive terminal | 10.Adjustment knob | 11.Digital tube displaying | 12.Shift keys                      |
| 13.Lock button                     |                    |                            |                                    |



**Back panel**

|  |   |   |
|--|---|---|
| 1 . Communication interface (standard RS232, optional RS485, USB, LAN) | 2. Aircraft control interface function (customized) | 3. The external trigger interface of the BNC interface (customized) |
| 4. Fan   | 5. Power outlet (including fuse holder)             | 6. Shell grounding terminal   |

### 1.4 Keyboard Description

#### Key notes

The front panel features a total of 24 keys (excluding the POWER key). The text above each key indicates its primary function, which can be executed by pressing the key directly. The text below each key indicates its secondary function. To activate the second -

ary function, first press the **【Shift】** key until its indicator light illuminates, then press the desired key. Each key press is accompanied by an audible “beep” confirmation. (if the buzzer is enabled).

| Key name | Primary function              | Secondary function | Key name | Primary function               | Primary function |
|----------|-------------------------------|--------------------|----------|--------------------------------|------------------|
| 0        | Enter the number 0            | Not tailored       | 7        | Enter the number 7             | Not tailored     |
| 1        | Enter the number 1            | Not tailored       | 8        | Enter the number 8             | Not tailored     |
| 2        | Enter the number 2            | Not tailored       | 9        | Enter the number 9             | Not tailored     |
| 3        | Enter the number 3            | Not tailored       | .        | Enter decimal point            | Not tailored     |
| 4        | Enter the number 4            | Not tailored       | ←、→      | Move cursor left and right     | None             |
| 5        | Enter the number 5            | Not tailored       | ↑、↓      | Up and down, add/subtract keys | None             |
| 6        | Enter the number 6            | Not tailored       | Enter    | Confirmation key               | None             |
| U        | Setting voltage               | Not tailored       | I        | Setting current                | Not tailored     |
| Save     | Save                          | Not tailored       | Call     | Retrieval                      | Not tailored     |
| Output   | Output on or off              | None               | Lock     | Lock                           | Menu             |
| Shift    | Select the secondary function | None               | Esc      | Escape key                     | None             |

## 2. Operation Declaration

### 2.1 Front Panel Operation Instructions

- (1) The units of voltage and current in this instrument and the manual are volts (V) and amperes (A).
- (2) This instrument is set to the front panel operation mode when it leaves the factory. When the power is on, you can set the instrument as required on the panel.

### 2.2 Parameter input

#### 2.2.1 Input through numeric keypad

Use 0~9 to enter the value you want to set, then press [Enter] to confirm. If there is an error in data input, press [Esc] to clear the current data, and then re-enter the data.

#### 2.2.2 Input through knob

In practical applications, continuous signal adjustment is sometimes required, which can be achieved using the digital adjustment knob. Pressing the shift keys [◀] or [▶] allows the cursor indicator to move left or right. The knob on the panel is a digital adjustment knob. Turning the knob clockwise increments the digit at the cursor position by one and carries over to the next higher place value. Turning the knob counterclockwise decrements the digit at the cursor position by one and borrows from the next higher place value. When entering data using the knob, the changed digit takes effect immediately.

### 2.3 Output Voltage Setting

Press [U] key, voltage display window flashes.

Method 1: Press the 0~9 number keys and press the [Enter] key to set the output voltage.

Method 2: Use the [◀] or [▶] key to move the cursor to the specified bit,

and rotate the knob to adjust the voltage setting. For example: set the output voltage to 32.000V.

Press [U] [3] [2] [.] [0] [0] [0] [Enter], the digital tube displays the input voltage value.

### 2.4 Output Current Setting

Press [I] key, the current display window flashes.

Method 1: Press the 0~9 number keys and press the [Enter] key to set the output voltage.

Method 2: Use the [◀] or [▶] key to move the cursor to the specified bit,

and rotate the knob to adjust the voltage setting. For example: set the output voltage to 10.000A.

Press [I] [1] [0] [.] [0] [0] [0] [Enter], the digital tube displays the input current value.

### 2.5 Overvoltage Protection Setting

Overvoltage protection is a feature that activates to safeguard the power supply and DUT when the output voltage exceeds the overvoltage threshold. Before operation, enable the overvoltage protection function and set the overvoltage protection threshold. When the output voltage surpasses this limit, the output immediately shuts off and the “OVP” indicator on the panel illuminates. Additionally, voltage adjustment is restricted to this protection value.

Avoid applying external voltages exceeding 120% of the rated voltage to the output terminals, as this may damage internal components!

After the power supply enters overvoltage protection mode, investigate external causes. Once external factors are eliminated, use the ON/OFF button to reactivate the protection.

### 2.5.1 Overvoltage Protection Value Setting

Click [▲] and [▼] to enter the operation parameter menu, and then click [OVP-S.] to edit the protection threshold.

Method 1: Press 0~9, the number key and press [Enter] to set the overvoltage protection value.

Method 2: Use the [◀] or [▶] key to move the cursor to the specified bit, and rotate the knob to adjust the overvoltage protection setting.

For example, the overvoltage protection voltage value is set to 33.0V.

Press [▲] and [▼] to flip the page until you reach [OVP-S] and press [3] [3] [.] [0] [Enter].

### 2.5.2 Overvoltage Protection Status Setting

Press [▲] and [▼] to flip the page to the operation parameter menu, and then flip to [OVP-E.] to modify the protection function status: ON/OFF.

## 2.6 Overcurrent Protection Setting

Overcurrent protection activates when the load current exceeds the preset threshold. Before operation, enable the overcurrent protection function and set the protection threshold. When the load current surpasses this limit, the output immediately shuts off and the “OCP” indicator on the panel illuminates. Furthermore, the current adjustment range is restricted by this protection value.

### 2.6.1 Overcurrent Protection Value Setting

Click [▲] and [▼] to enter the operation parameter menu, and then click [OCP-S.] to edit the protection threshold.

Method 1: Press 0~9, the number key and press [Enter] to set the overvoltage protection value.

Method 2: Use the [◀] or [▶] key to move the cursor to the specified bit, and rotate the knob to adjust the overcurrent protection setting.

For example, the overvoltage protection voltage value is set to 11.0A.

Press [▲] and [▼] to flip the page until you reach [OVP-S] and press [1] [1] [.] [0] [Enter].

### 2.6.2 Overcurrent Protection Status Setting

Press [▲] and [▼] to flip the page to the operation parameter menu, and then flip to [OCP-E.] to modify the protection function status: ON/OFF.

## 2.7 Output Delay Time Setting (this Function Is Invalid in This Series of Conventional Machines)

Press [Shift], press [Lock] again, press [▲] and [▼] to turn the page to the running parameter menu, and then turn to [DELAY] to modify the delay parameters.

Note: This Delay setting only works when the cycle is automatically executed, so when the memory is stored, this Delay setting is also stored in the memory location.

## 2.8 Function Setting

Press [Shift], then [Lock], followed by [▲] and [▼] to navigate through menu items. Press [▼] to switch pages, The menu items are as follows: INIT (Factory Reset); OUT (Output Status); V-M (Maximum Voltage Input); I-M (Maximum Current Input); BAUD (Communication Port baud Rate); BEEP (Beep); H.K. (Hot Key); V SELF (Automatic Voltage Tuning); ADDR (Communication Address); SENSE (Compensation Function); COM-P (Communication Protocol); SL-ON (Slow Start); EC- (Encoder Setting); VER (Version Number); T-S (Trigger Mode); T-F (Trigger Function); A-OFF (Automatic Turn-off Time); T-DAT (Current Offset); WL-MR (Line Loss Compensation).

### 2.8.1 Function Restore Factory Settings

Press [Shift], then press [Lock] to enter the MENU. Press [▲] and [▼] key to flip pages, displaying "INIT". Use [▲] [▼] keys or the knob to enable this feature. Once activated, the MENU interface will pop up, allowing all settings to be reset to factory defaults.

### 2.8.2 Output State Memory Function

Press [Shift], press [Lock] to enter the MENU. Press [▲] and [▼] key to flip the page, and display "OUT". Use [▲] [▼] keys or knobs to select functions.

Function item: 0-F. DF means that the power is not output and the default parameters are restored (5V 1A);  
1-F. ST indicates that the power is not output and the user's set parameters are restored;  
2-O. ST means to turn on the output and restore the user's set parameters.

### 2.8.3 Maximum input voltage limit

Press [Shift], press [Lock] to enter MENU, press [▲] and [▼] to turn the page, and display "V-M", using the numeric keypad or knob to set parameters.

The parameters set by this function will limit the maximum voltage setting for [U-CV] or communication. For example, if the U Max parameter is set to 15V, the [U-CV] or communication command setting voltage will be limited to a maximum of 15V.

### 2.8.4 Maximum input current limit

Press [Shift], then press [Lock] to enter the MENU. Press [▲] up and [▼] down to flip the page. The display shows "I-M", indicating that it refers to "V-M".

### 2.8.5 RS232 Port baud rate setting

Press [Shift], press [Lock] and then enter MENU. Press [▲] up and [▼] down to flip the page until "BAUD" is displayed. Set the code corresponding to the baud rate with the knob, so that the device meets the requirements of the baud rate when the computer is remotely controlled.

The following table shows the code table corresponding to the port rate:

|           |      |      |      |      |       |       |       |        |
|-----------|------|------|------|------|-------|-------|-------|--------|
| code      | 1.2K | 2.4k | 4.8K | 9.6K | 19.2K | 38.4K | 57.6K | 11.52K |
| Baud rate | 1200 | 2400 | 4800 | 9600 | 19200 | 38400 | 57600 | 115200 |

## 2.8.6 Beeper Settings

Press [Shift], press [Lock], press [▲] and [▼] to flip the page, and select the corresponding menu item.

## 2.8.7 Hotkey Settings

Press [Shift], then [Lock], followed by [▲] and [▼] to flip the page. The display will show "H.K." Use [▲] and [▼] keys or the knob to enable or disable this feature. Once activated, pressing any number key (0-9) will retrieve the corresponding settings from memory for the respective group (0-9).

## 2.8.8 Voltage Self-Test Function Setting

Press [Shift], press [Lock], press [▲] and [▼] to turn the page, and display "V. SELF". Use [▲] and [▼] keys or knobs to open or close.

After this function is enabled, the output voltage value of the automatic monitoring is adjusted to reduce the deviation between the set voltage value.

## 2.8.9 Communication address setting

Press [Shift], press [Lock] again, press [▲] and [▼] to turn the page, and display "ADDR". You can set the required address by using [▲] [▼] keys, knob or numeric keys.

Note: The address range is 1 to 250.

## 2.8.10 Remote Sensing Function Setting

When the load consumes a large current, a voltage drop occurs in the connection line between the power supply and the load terminal. In a constant voltage state, remote sensing can automatically compensate for the voltage drop of the load line.

Before using the remote sensing function, you must first set the power supply to remote sensing mode, and the remote sensing function can only be enabled when the output is turned off. Use twisted-pair wiring for the Sense leads whenever possible, and avoid tangling them with the load wires.

Press [Shift], press [Lock], press [▲] and [▼] to flip the page, select the corresponding menu SENSE, and use [▲] [▼] keys or knobs to open or close.

Schematic diagram of power supply remote measurement wiring:

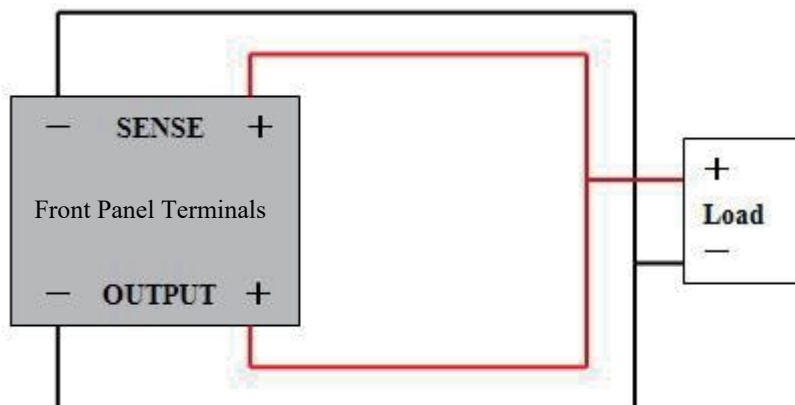

## 2.8.11 Communication Protocol Selection

Press [Shift], press [Lock] again, press [▲] and [▼] to turn the page up and down, and display "COM-P". Use [▲] [▼] keys or knobs to select SCPI or Modbus protocol.

### 2.8.12 Slow Startup Settings

Press [Shift], press [Lock] again, press up [▲] and down [▼] to turn the page, and display "SL-ON". Use [▲][▼] keys or knobs to select functions.

Function item: OFF means to turn off the slow start function;

CV indicates the rising time of increased voltage in constant voltage mode;

CC indicates the increase in current rise time under constant current mode.

### 2.8.13 Encoder Setup Mode

Press [Shift], then press [Lock], press up [▲] and down [▼] to turn the page, and display "EC-". Use [▲] [▼] keys or knobs to select functions.

Function items: O. N means to turn off the encoder setting function;

1. S U means that there is no need to press the [V-set], and the voltage can be adjusted directly through the rotary encoder;

2. S I means that there is no need to follow the [I-set], and the current size can be adjusted directly through the rotary encoder.

### 2.8.14 View Software Version

Press [Shift], press [Lock], press up [▲] and down [▼] to flip the page, and select the corresponding menu "VER".

### 2.8.15 Trigger Setting

Press [Shift], press [Lock], press up [▲] and down [▼] to turn the page, display "T-S", use [▲] [▼] keys or knobs to select functions.

Function item: 0-IMM means that the communication command is triggered;

1-EXT means external trigger;

2-PUL indicates pulse triggering;

3-LEL indicates low level trigger.

### 2.8.16 Trigger Function Setting

Press [Shift], press [Lock] again, press up [▲] and down [▼] to turn the page, display "T-F", use [▲] [▼] keys or knobs to select functions.

0-Out means that the state of the output switch changes once for each trigger. If it was open, it will be closed after one trigger, and vice versa;

### 2.8.17 Scheduled Output Shutdown Setting

Press [Shift], press [Lock] again, press up [▲] and down [▼] to turn the page, and display "A-OFF", use the numeric keypad or knob to set parameters.

This function can achieve 0 ~99999s timed output, when the output reaches the set time, will automatically close the output.

### 2.8.18 Current Offset

Press [Shift], press [Lock] again, press [↑] and [↓] key to turn the page, and display "T-DAT" to view the current offset when output is empty.

This function is available under no-load output conditions. If the current output display is not zero, press [Shift] + [Esc] to clear the current offset and save it to "T-DAT".

### 2.8.19 Line Loss Compensation Setting

Press [Shift], press [Lock], press [↑] and [↓] key to turn the page, and display "WL-mR". Use [↑] [↓] keys, knob or numeric keypad to set the line resistance value (mR).

### 2.8.20 Store Operation

The power supply can store commonly used parameters in 100 non-volatile memory units, allowing users to retrieve them conveniently and quickly. The stored data includes output voltage values, output current values, overvoltage protection values, overcurrent protection values, overvoltage protection status, overcurrent protection status, and delay time.

Press [Save], set the knob group number, press [Enter] ENTER, save the current running parameters

For example: store is set to memory address 5.

Press [Save] [5] [Enter].

### 2.8.21 Retrieval operation

Press [Call] to set the group number of the knob, and press [Enter] to retrieve the running parameters of the group

For example: call set, memory address is 5.

Press [Call] [5] [Enter].

## 2.9 Out Switch

The [On/off] key on the front panel controls the opening and closing of the output.

## 2.10 Lock Function

The [Lock] key on the front panel can be turned on/off to enable the keyboard lock function. After pressing the [Lock] key, when other keys are pressed, the digital tube will display "-L-L-L-L", and all other keys and knobs except the [Lock] key and [On/off] key are locked.

## 2.11 Adjustment Knob

Press the adjustment knob to switch the cursor position.

## 2.12 Protection Functions

This product provides overvoltage, overcurrent, overtemperature protection function.

Over temperature (OTP) protection function. When operating this instrument, abnormal high temperature is generated, the instrument will automatically turn off the output, to ensure the safety of users and the use of the instrument.

## 2.13 Operation Mode Description

### 2.13.1 Constant Voltage Operation Mode

- (1) Connect the load to the output

For safety of use, connect the load to the (+) and (-) terminals of the output with the output closed.

- (2) Enter the desired current limit value

Press [I] to enter the current setting input mode. In this input mode, you can use the numeric keypad or knob to set the desired current setting.

- (3) Enter the voltage value to be output

Press [U] to enter the voltage setting value input mode. In this input mode, you can use the numeric keypad or knob to set the desired voltage setting value.

- (4) Launch the output

After pressing [On/Off], the output is turned on, and the display shows the actual output measurement value.

- (5) Confirm that the power supply is in constant voltage mode

Please check if the CV light is on to ensure that the output is operating in constant voltage mode. If the CC light is on, increase its current limit to ensure that the output is operating in constant voltage mode.

### 2.13.2 Constant Current Operation Mode

- (1) Connect the load to the output

For safety of use, connect the load to the (+) and (-) terminals of the output with the output closed.

- (2) Enter the desired voltage limit

Press [U] to enter the voltage setting value input mode. In this input mode, you can use the numeric keypad or knob to set the desired voltage setting value.

- (3) Enter the current value to be output

Press [I] to enter the current setting value input mode. In this input mode, you can use the numeric keypad or knob to set the desired current setting value.

- (4) Launch the output

After pressing [On/Off], the output is turned on, and the display shows the actual output measurement value.

- (5) Confirm that the power supply is in constant current mode

Please check if the CC light is on to ensure that the output is operating in constant current mode. If the CV light is on, increase its voltage limit to ensure that the output is operating in constant current mode.

### 2.13.3 Constant Voltage/current State Switching

When operating in output mode, the power supply maintains constant voltage (green indicator light on) until the output current reaches the preset threshold. Upon reaching this threshold, it switches to constant current mode (red indicator light on), automatically adjusting between constant voltage and constant current states based on load requirements.





### 3. Telecontrol

This series of power supply supports remote control mode, provides RS232 interface or USB interface to communicate with the computer, and realizes all functions on the panel through the upper computer software.

#### 3.1 Interface Settings

##### 3.1.1 Interface

RS232, RS485, USB and LAN interfaces can be installed on the back panel of the instrument, as shown in the figure below.

|   |   |   |   |
|---|---|---|---|
|  |  |  |  |
| RS232 interface   | RS 485 interface  | USB interface   | Internet interface  |

##### 3.1.2 Communication Settings

Set up the COM port on your PC according to the following

- (1) Baud rate:9600
- (2) Check bit: None
- (3) Data bits: 8
- (4) Stop position: 1
- (5) Data flow control: None

**Note 1:** If the power supply does not respond to remote control, please check:

- Whether the interface line itself is disconnected.
- Check whether the interface cable and power supply are correctly connected to the corresponding PC pins.
- Whether the interface cable is fastened.
- The communication parameters of the remote control program are consistent with 3.1.2.
- Whether the command terminator of the remote control program is a line break (hex 0X0A).

#### 3.2 SCPI Programming Instruction Set

Refer to the programming manual for details of the SCPPI programming instruction set.

## 4. Maintenance

### 4.1 Periodic Inspection

- In the process of using the product, in order to ensure that the product can achieve its best working state, please do regular inspection.
- Check whether the power supply input socket is burned out. Check whether the power output terminal is loose.

### 4.2 Replacement of Fuse

step : (1) Unplug the power cord and remove the fuse box with a small screwdriver.

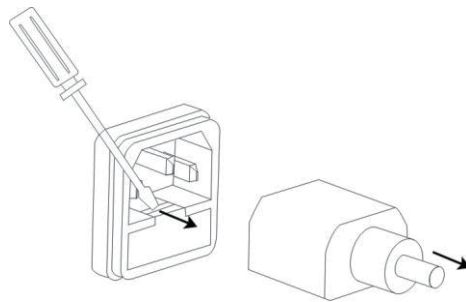

(2) Replace fuse.

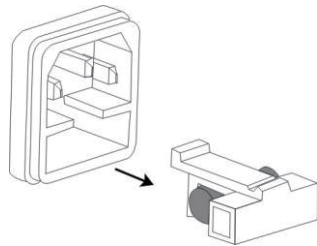

Fuse specification: T10AL/250V

## 5. Product specification

When using this specification, please ensure that the machine is turned on for more than 30 minutes. **Table 1:**

| Model                                 | 30V3A   | 30V5A   | 30V10A  | 60V3A   | 60V5A   |
|---------------------------------------|---|---------|---------|---------|---------|
| <b>Rated output (0°C~40°C)</b>        |   |         |         |         |         |
| Voltage                               | 0~30V   | 0~30V   | 0~30V   | 0~60V   | 0~60V   |
| Current                               | 0~3A  | 0~5A    | 0~10A   | 0~3A    | 0~5A    |
| Overvoltage protection                | 0.1~33V   | 0.1~33V | 0.1~33V | 0.1~65V | 0.1~65V |
| Overcurrent protection                | 0.1~4A  | 0.1~6A  | 0.1~11A | 0.1~4A  | 0.1~6A  |
| <b>Voltage output</b>                 |   |         |         |         |         |
| Line regulation                       | ≤0.01%+3mV  |         |         |         |         |
| Load regulation                       | ≤0.01%+3mV(I≤3A)/≤0.01%+5mV(I>3A)   |         |         |         |         |
| Recovery time                         | ≤100us(50% load change, minimum load 0.5A)  |         |         |         |         |
| Ripples and noise                     | ≤1mV rms(I≤3A)(5Hz~1MHz)/≤2mV rms(I>3A)(5Hz~1MHz)   |         |         |         |         |
| Temp. coefficient                     | ≤100ppm/°C  |         |         |         |         |
| Set precision                         | ±(0.03% of reading + 10mV)(25±5°C)  |         |         |         |         |
| Set resolution                        | 1mV (5 bits)/0.1mV (6 bits)   |         |         |         |         |
| <b>Current output</b>                 |   |         |         |         |         |
| Power effect                          | ≤0.01%+3mA  |         |         |         |         |
| Load effect                           | ≤0.01%+3mA(I≤3A)/≤0.01%+5mA(I>3A)   |         |         |         |         |
| Ripples and noise                     | ≤3mA rms(I≤3A)/≤6mA rms(I>3A)   |         |         |         |         |
| Set precision                         | ±(0.02% of reading + 0.1% of FS) (25±5°C)   |         |         |         |         |
| Set resolution                        | 0.1mA(10A resolution above 1mA)(5-bit); 0.01mA(10A resolution above 0.1mA)(6-bit)   |         |         |         |         |
| <b>Display</b>                        |   |         |         |         |         |
| Voltage                               | 5 digits display/6 digits display   |         |         |         |         |
| Current                               | 5 digits display/6 digits display   |         |         |         |         |
| Voltage resolution                    | 1mV (5 bits)/0.1mV (6 bits)   |         |         |         |         |
| Current resolution                    | 0.1mA(10A resolution above 1mA)(5-bit); 0.01mA(10A resolution above 0.1mA)(6-bit)   |         |         |         |         |
| <b>Accuracy of reading</b>            | ±(0.02% of reading+5mV)(25±5°C); ±(0.02% of reading + 0.1% of FS) (25±5°C)  |         |         |         |         |
| <b>Protection</b>                     | Overload protection, polarity reversal protection, overvoltage protection, overcurrent protection, overtemperature protection       |         |         |         |         |
| <b>Lock function</b>                  | have  |         |         |         |         |
| <b>Programming interface</b>          | RS232,485 (optional), aviation alarm interface (optional), analog control interface (optional), LAN interface (optional)            |         |         |         |         |
| <b>Programming protocol</b>           | Compatible Modbus, SCPI protocol  |         |         |         |         |
| <b>Storage and retrieval</b>          | 100 Group storage, contains 10 groups of quick parameter storage  |         |         |         |         |
| <b>Insulativity</b>                   | Output terminals to the housing or other terminals; ≤ 60VDC   |         |         |         |         |
| <b>Operational environment</b>        | Indoor use elevation: ≤2000m ambient temperature: 0°C~40°C<br>relative temperature: ≤80% Installation level: II Pollution degree: 2 |         |         |         |         |
| <b>Storage environment</b>            | Environment temperature: -10 ~ 70°C relative temperature: ≤70%  |         |         |         |         |
| <b>Input</b>                          | AC220V±10%,50/60Hz  |         |         |         |         |
| <b>Appendix</b>                       | Power cable * 1, PC software CD 1, RS232 interface cable * 1, USB communication cable * 1   |         |         |         |         |
| <b>Size (without protective case)</b> | 376(D)× 215(W)× 89(H)mm   |         |         |         |         |
| <b>Weight</b>                         | About 7kg, Each model is different  |         |         |         |         |

Table 2:

| Model                                 | 150V1A  | 150V2A   | 150V3A   | 250V1A   |
|---------------------------------------|---|----------|--|----------|
| <b>Rated output (0°C~40°C)</b>        |   |          |  |          |
| Voltage                               | 0~150V  | 0~150V   | 0~150V   | 0~250V   |
| Current                               | 0~1A  | 0~2A     | 0~3A   | 0~1A     |
| Overvoltage protection                | 0.1~153V  | 0.1~153V | 0.1~153V   | 0.1~253V |
| Overcurrent protection                | 0.1~1.5A  | 0.1~2.5A | 0.1~3.5A   | 0.1~1.2A |
| <b>Voltage output</b>                 |   |          |  |          |
| Line regulation                       | ≤0.01%+3mV  |          |  |          |
| Load regulation                       | ≤0.01%+3mV(I≤3A)/≤0.01%+5mV(I>3A)   |          |  |          |
| Recovery time                         | ≤100us(50% load change,minimum load 0.5A)   |          |  |          |
| Ripples and noise                     | ≤1mV rms(I≤3A)(5Hz~1MHz)/≤2mV rms(I>3A)(5Hz~1MHz)   |          |  |          |
| Temp. coefficient                     | ≤100ppm/°C  |          |  |          |
| Set precision                         | ±(0.03% of reading + 10mV)(25±5°C)  |          |  |          |
| Set resolution                        | 1mV (5 bits); 0.1mV (6 bits)  |          |  |          |
| <b>Current output</b>                 |   |          |  |          |
| Line regulation                       | ≤0.01%+3mA  |          |  |          |
| Load regulation                       | ≤0.01%+3mA(I≤3A)/≤0.01%+5mA(I>3A)   |          |  |          |
| Ripples and noise                     | ≤3mA rms(I≤3A)/≤6mA rms(I>3A)   |          |  |          |
| Set precision                         | ±(0.02% of reading + 0.1% of FS) (25±5°C)   |          |  |          |
| Set resolution                        | 0.1mA(5 bits); 0.01mA(6 bits)   |          |  |          |
| <b>Display</b>                        |   |          |  |          |
| Voltage                               | 5 digits display/6 digits display   |          |  |          |
| Current                               | 5 digits display/6 digits display   |          |  |          |
| Voltage resolution                    | 1mV (5 bits); 0.1mV (6 bits)  |          |  |          |
| Current resolution                    | 0.1mA(5 bits); 0.01mA(6 bits)   |          |  |          |
| Accuracy of reading                   | ±(0.02% of reading+5mV)(25±5°C); ±(0.02% of reading + 0.1% of FS) (25±5°C)  |          |  |          |
| <b>Protection</b>                     | Overload protection, polarity reversal protection, overvoltage protection, overcurrent protection, overtemperature protection |          |  |          |
| <b>Lock function</b>                  | have  |          |  |          |
| <b>Programming interface</b>          | RS232,485 (optional), aviation alarm interface (optional), analog control interface (optional), LAN interface (optional)      |          |  |          |
| <b>Programming protocol</b>           | Compatible Modbus, SCPI protocol  |          |  |          |
| <b>Storage and retrieval</b>          | 100 Group storage, contains 10 groups of quick parameter storage  |          |  |          |
| <b>Insulativity</b>                   | Output terminals to the housing or other terminals; ≤60VDC  |          |  |          |
| <b>Operational environment</b>        | Indoor use elevation: ≤2000m<br>relative temperature: ≤80% Installation level: II   |          | ambient temperature: 0°C~40°C<br>Pollution degree: 2 |          |
| <b>Storage environment</b>            | Environment temperature: -10 ~ 70°C relative temperature: ≤70%  |          |  |          |
| <b>Input</b>                          | AC220V±10%,50/60Hz  |          |  |          |
| <b>Appendix</b>                       | Power cable * 1, PC software CD 1, RS232 interface cable * 1, USB communication cable * 1                                     |          |  |          |
| <b>Size (without protective case)</b> | 376(D)×215(W)×89(H)mm   |          |  |          |
| <b>Weight</b>                         | About 7kg, Each model is different  |          |  |          |